

TripleAir MD 55-37 CEILING Grid

TripleAir 55mm T-bar grid

TripleAir 55mm T-Bar grid is designed as a Cleanroom ceiling in a modular frame construction for non-pressurized applications, consisting of 6000mm long main T-profiles and cut-to-size cross T-profiles. Suitable up to Class 3 to ISO.EN14644-1

Designed as a non-walk on frame construction with high deflection strength, consisting of 55mm wide aluminium extrusion main and cross runners of identical shape, connected with galvanised clips to form a modular grid system. Aluminium extrusion with standard RAL9010G white finish.

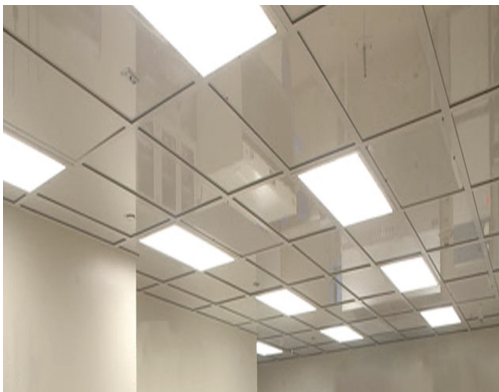

TripleAir 55mm T-bar extrusion profiles have an identical geometry, allowing for a tight connection and preventing uncontrolled particle deposition during installation.

All ceiling filter elements, such as filters and lay-in lights, shall be installed from the deck of the ceiling grid, minimizing interruptions in the cleanroom. Gaskets between ceiling grid and filters, blanks and other inserts are provided for, with a one-side adhesive gasket, installed into each opening.

All seals shall be resistant to water, oil, steam, alcohol, acids and alkaline.

Clean Room Filtration and Lighting Technology

TripleAir Technology are suppliers of high quality HEPA and ULPA filtration, ceiling grid systems and luminaires for the clean room industry. We offer fully integrated ceiling solutions for projects and cleanroom facilities.

T +44(0)1670 739394

E info@tripleairtechnology.co.uk

Document TAT 008-4

tripleairtechnology.co.uk

TripleAir MD 55-37 CEILING Grid

The TripleAir 55-37 HD Grid is suitable for the installation of the following products:-

TripleAir Fan Filter Units.
 HEPA/ULPA filters & TripleHood Filter Modules
 Blank panels & acoustic panels
 Exhaust hoods and perforated plates
 Integrated recessed luminaires
 Teardrop luminaires
 Air deflection Curtains
 Cleanroom partitions

TripleAir 55mm T-Bar grid profiles are connected by means of top plates bolted on top of every profile connection.

Tee Joint

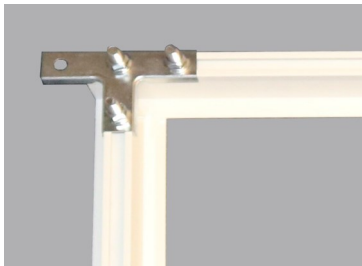

cross Joint

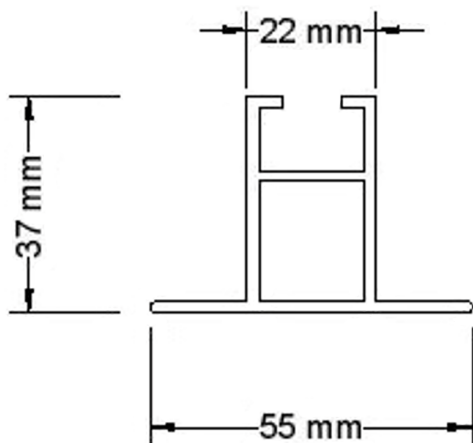
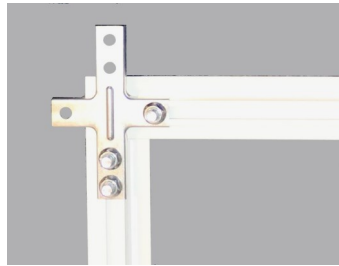

STANDARD FEATURES:-

- RAL9010G epoxy powder coating
- 600x1200mm centres
- Own weight appx 12kg/m²
- Additional surface loads 0.75kn/m²
- M10 hanger (turnbuckle down)
- Maximum 3mm deflection
- 37mm perimeter angle trim
- Fixing accessories
- EPDM gasket (white)
- Overall ceiling element = grid dimension minus 30mm (max)

OPTIONS:-

- Anodised finish
- Alternative paint colours
- 1200x1200mm & 600x600mm centres
- Threaded bar
- Blank pans
- Perforated pans
- Honeycomb panels
- Hold down clamps for pans
- Diffusers
- Lay-In lights
- Teardrop lights
- Air deflection curtains
- Light duty 37mm width option

Clean Room Filtration and Lighting Technology

Visit our website to view our full range of HEPA and ULPA filters, safe change units, fan filter units, ceiling grid systems and cleanroom luminaires.

T +44(0)1670 739394
 E info@tripleairtechnology.co.uk

TripleAir MD 55-37 CEILING Grid

Ceiling Grid Assembly

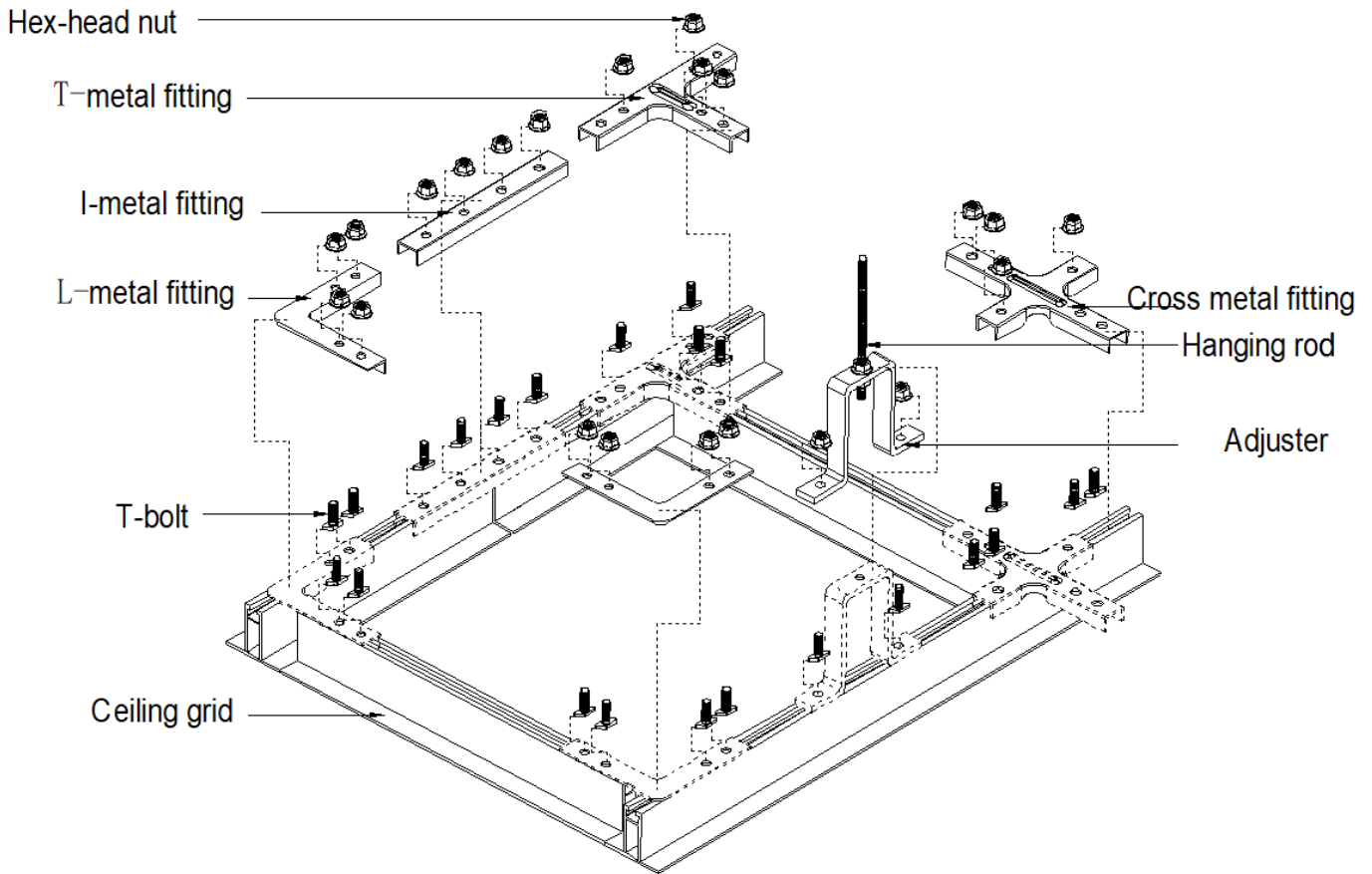

Related Products

Fan Filter Units



Hood Filters



Teardrop |Luminaires



Recessed Luminaires

