

# TripleAir SIDE ACCESS IN-LINE Housing

## Description

The SA In-Line Compact Filter Housing is designed for horizontal installation and comprises of a galvanized in-line duct section, provided with side-access door, left-hand or right-hand in direction of airflow (option both sides) and the necessary number of welded holding frame provisions complete with support angles.

The housing is 500 mm deep in the direction of the air stream.

The packaged unit is designed to provide direct duct or plenum installation without additional sub-frames.

The housing is designed to hold Pre and secondary filters with slide in headers in single or multiple banks

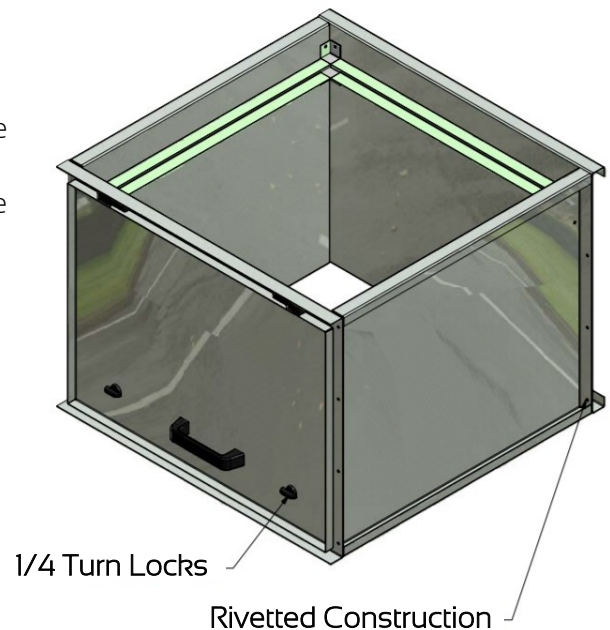

| Model | Airflow        | Pre filter                      | Main filter                     |
|-------|----------------|---------------------------------|---------------------------------|
| 1-1   | Up to          | 1 x 600 x 600 x                 | 1 x 592 x 592                   |
| 1-2   | Up to          | 2 x 600 x 600 x                 | 2 x 592 x 592                   |
| 2-2   | Up to<br>16000 | 4 x 600 x 600 x<br>50 or 100mm  | 4 x 592 x 592<br>bag or Compact |
| 2-3   | Up to<br>24000 | 6 x 600 x 600 x<br>50 or 100 mm | 6 x 592 x 592<br>bag or Compact |

All SA In-Line Compact Filter Housing are assembled, palletized and wrapped. Filters are packed separately for installation on-site.

## Clean Room Filtration and Lighting Technology

TripleAir Technology are suppliers of high quality HEPA and ULPA filtration, ceiling grid systems and luminaires for the clean room industry. We offer fully integrated ceiling solutions for projects and cleanroom facilities.

# TripleAir SIDE ACCESS IN-LINE Housing

## Dimensions

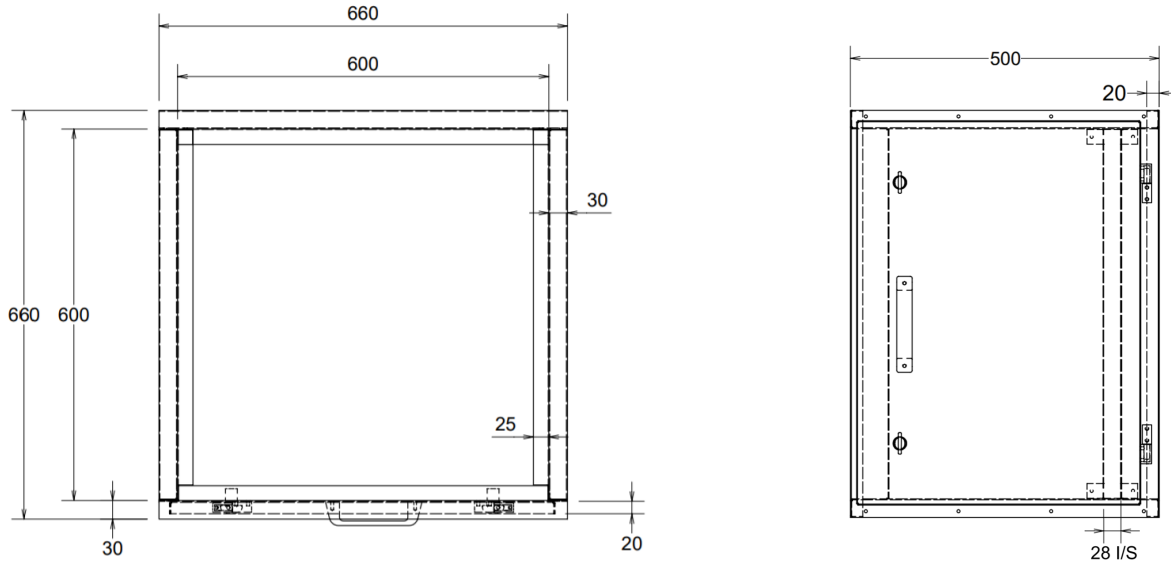

| Flange Width  | 660mm                           | 1260mm                           | 1860mm                           | 2460mm                           |
|---------------|---------------------------------|----------------------------------|----------------------------------|----------------------------------|
| Flange Height | Qty of filters<br>(592mmx592mm) | Qty of filters<br>(592mm x592mm) | Qty of filters<br>(592mm x592mm) | Qty of filters<br>(592mm x592mm) |
| 660mm 1H      | 1                               | 2                                | 3                                | 4                                |
| 1260mm 2H     | 2                               | 4                                | 6                                | 8                                |
| 1860mm 3H     | 3                               | 6                                | 9                                | 12                               |
| 2460mm 4H     | 4                               | 8                                | 12                               | 16                               |

## Related Products

### S-COMP Filters



TripleAir Technology Ltd  
 (Sales, Engineering & Manufacture)  
 41A Colbourne Crescent,  
 Nelson Park Industrial Estate,  
 Cramlington, England,  
 NE23 1WB.  
**T** +44(0)1670 739394  
**E** info@tripleairtechnology.co.uk  
 Document TAT 002-02



TripleAir Technology BV (Sales & Production)  
 P.O. Box 2204, 7801 CE, Emmen  
 Columbusstr. 30, 7825 VR, Emmen,  
 The Netherlands  
**T** +31(0)591 630607 **F** +31(0)591 631099

[tripleairtechnology.co.uk](http://tripleairtechnology.co.uk)